

ABSOLUTE MAXIMUM RATINGS

Item	Symbol	Min.	Max.	Unit
Supply Voltage(Logic)	VDD-VSS	-0.3	7.0	V
Supply Voltage(LCD)	VDD-VO	-0.3	13.0	V
Input Voltage	VI	-0.3	VDD+0.3	V
Operating Temp.	Topr	-20	70	°C
Storage Temp.	Tstg	-30	80	°C

MECHANICAL DATA

Item	Nominal Dimensions	Unit
Module Size(W x H x T)	70.6 x 27.4 x 13.0	mm
Viewing Area(W x H)	60.5 x 18.5	mm
Dot Pitch(W x H)	0.40 x 0.45	mm
Dot Size(W x H)	0.36 x 0.41	mm
Weight	Approx. 40	g

ELECTRICAL CHARACTERISTICS (VDD=5V±5%)

Item	Symbol	TEST Condition	Min.	Typ.	Max.	Unit
Input High Voltage	VIH	--	VDD-1.2	--	VDD	V
Input Low Voltage	VIL	--	0	--	0.8	V
Output High Voltage	VOH	--	VDD-0.3	--	VDD	V
Output Low Voltage	VOL	--	0	--	0.3	V
Supply Current	IDD	VDD=5.0v	--	0.5	0.8	mA
LCD Driving Voltage	VDD-VO	Ta=25°C	--	6.5	--	V

PIN CONNECTIONS

PIN	Symbol	Level	Function
1	VDD	+5V	Power supply for logic
2	VSS	0V	GND
3	VO	--	Contrast adjusting
4	/RST	L	Reset signal, active "L"
5	E1	H,H→L	Enable signal for IC1
6	E2	H,H→L	Enable signal for IC2
7	R/W	H/L	H: Read L: Write
8	A0	H/L	H: Data L: Instruction code
9	DB0	H/L	Data bus line
10	DB1	H/L	
11	DB2	H/L	
12	DB3	H/L	
13	DB4	H/L	
14	DB5	H/L	
15	DB6	H/L	
16	DB7	H/L	
17	LED+	+5V	Power supply for LED backlight
18	LED-	0V	

BLOCK DIAGRAM

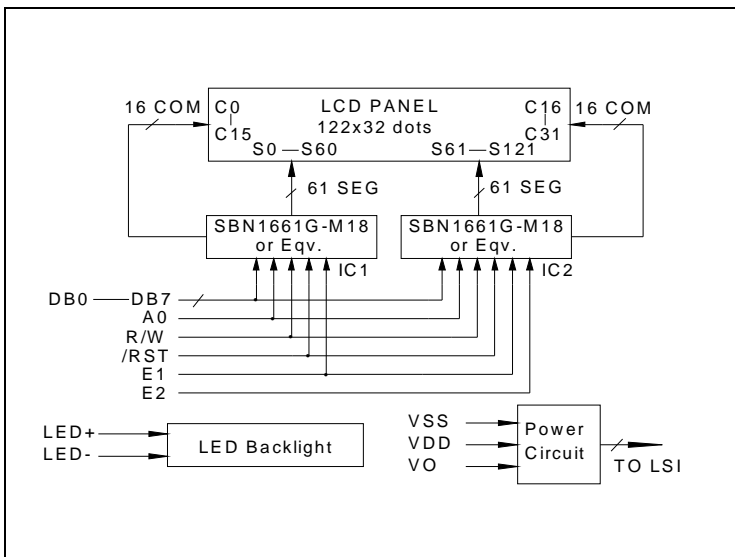

LED BACKLIGHT SPECIFICATIONS(Ta=25°C)

Item	Symbol	Typ.	Max.	Unit
Forward Voltage	Vf	3.1	3.3	V
Forward Current	If	30	--	mA
LED Color		White		